



CS-3

Scintrex Cesium Vapor Magnetometer Sensor

OPERATION MANUAL

SCINTREX

Rev	Description of change	ECO	Date of issue	App
1.0	Initial Release		Feb 21, 2002	G.H.
2.0	Additional information		Nov 30, 2005	G.M.
3.0	Additional information		Oct 30, 2006	G.M.
4.0	Additional information	4405	Jan 18, 2007	R.L.

CS-3 SCINTREX

Scintrex Cesium Vapor Magnetometer Sensor

Operation Manual

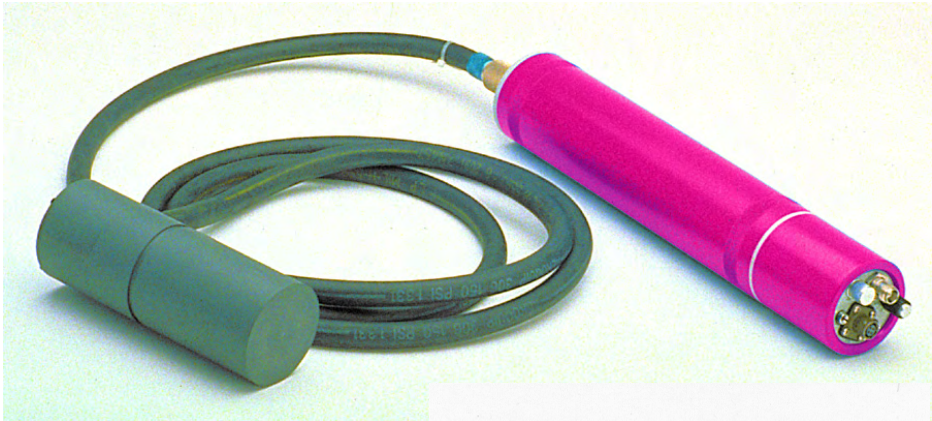

SCINTREX LIMITED

HEAD OFFICE

SCINTREX Limited
222 Snidercroft Road
Unit #1
Concord, Ontario
Canada, L4K 2K1
tel: +1 905 669 2280
fax: +1 905 669 6403
e-mail:
scintrex@scintrexltd.com

World-wide web: <http://www.scintrexltd.com>

Copyright © SCINTREX Limited 2005. All rights reserved.

No part of this publication may be reproduced, stored in a retrieval system or transmitted, in any form, or by any means, electronic, mechanical, photo-copying, recording, or otherwise, without prior consent from SCINTREX Limited.

Document Part No. 762701, Revision 3.0

Printed and bound in Canada



Foreword

Getting Started

About this manual	1-1
Page Numbering	1-1
Type Styles	1-2
Chapter Layout	1-3
Symbols	1-4
Understanding Instrument Basics	1-5
Sensor Head	1-5
Sensor Electronics	1-7
Old version	1-9
New version	1-9

Operating the CS-3 in the Field

Setting Up the CS-3	2-2
Mounting the CS-3	2-3
Powering Up	2-4
Obtaining the Larmor Signal	2-5
Setting the Operating Hemisphere	2-7
Operating in the Presence of Spurious Magnetic Fields	2-9

Orienting Your CS-3

Understanding the Active Zone of the CS-3	3-2
Using a Strapped Down CS-3 for Surveys	3-7
Calculating the Tumble Angle	3-7
Recommended Survey Orientations	3-18
Comparison with the Locked Oscillator	3-20

Maintaining Your CS-3 and Trouble-shooting

Trouble-shooting	4-2
-------------------------------	------------

Reference Information

CS-3 Technical Specifications	5-1
Instrument Parts List	5-3
CS-3 Standard Accessories	5-3
Warranty and Repair	5-3
Warranty	5-3
Repair	5-4



Shipping Instructions 5-4

Appendix A: Theory of Operation

System Overview A-1

Appendix B: CS-3 Block Diagram



Foreword

The CS-3 is an optically pumped cesium vapor magnetometer sensor used for scalar measurement of the Earth's magnetic field. As shown below, the CS-3 sensor consists of a sensor head with cable and sensor electronics.

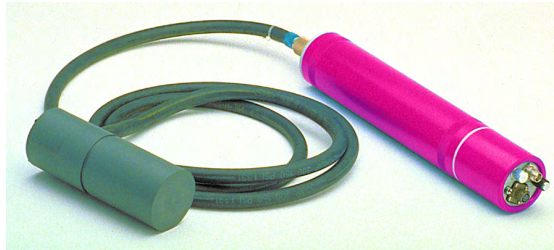

Figure 1: CS-3 Magnetometer Sensor

The system excels in a variety of applications (ex. airborne, satellite, marine and ground magnetometry or gradiometry, base station magnetometry and ferrous ordnance location) due to its:

- high sensitivity
- high cycling rates
- excellent gradient tolerance
- continuous output
- automatic hemisphere switching



- fast response
- low susceptibility to the electromagnetic interference

Magnetic field measurements performed by the CS-3 is based on quantum mechanics principles, and the phenomena of optical pumping and self-oscillation. When properly oriented in relation to the ambient magnetic field, cesium vapor in the sensor oscillates continuously by itself without any assistance. The frequency of oscillation (defined as the Larmor frequency) is proportional to the ambient magnetic field.

The sensor outputs a signal at the Larmor frequency which is normally processed by an external magnetometer processor linked to the system. The magnetometer processor converts the Larmor frequency into digital magnetic field readings and presents them for display and recording. Modern magnetic processors have a resolution of 0.001 nT and read 10 times each second or faster.

In summary, the CS-3 offers distinct and substantial benefits in measurement of magnetic fields due to the principles of both optical pumping and self-oscillation. These advantages are described in the next two sections.

Advantages of Optical Pumping

These benefits are shared by all well designed optically pumped magnetometers regardless of which atoms (cesium, rubidium, potassium or helium) are being pumped, and regardless which of two principles of operation is utilized (self oscillation, or locked oscillation).

High Sensitivity

Due to the narrow resonant linewidth and good signal to noise ratio the sensitivity of optically pumped magnetometers is in the range of few pT ($1\text{pT}=0.001\text{nT}$) in the measuring bandwidth of 1Hz. In contrast to the proton precession magnetometers, the sensitivity does not deteriorate as the measured ambient field decreases.

Continuous Signal

The operation of the optically pumped magnetometers is not cyclic. Highly sensitive readings could be obtained at the high repetition rate.



High Gradient Tolerance

Absorption cells of the optically pumped magnetometers in which the detection of the ambient field is taking place are normally much smaller than the sensors of proton precession (including Overhauser) magnetometers. Consequently, the field gradients over the sensor volume are much smaller and the proper operation of the magnetometer is much less affected, e.g. the volume of the CS-3 absorption cell is only 0.006 liters.

Low Radiated Electromagnetic Interference

Sensors of the optically pumped magnetometers radiate low disturbing EM fields. The H_1 field is the order of 10 nT. The RF field for the lamp excitation is well confined and of the high frequency - around 165 MHz for the CS-3.

Insensitivity to Motion Induced Doppler Effects

Irregular motion of the platform carrying the sensor modulates (adds to) the precession frequency and introduces noise into the measurements of the magnetic field.

Proton precession (including Overhauser) magnetometers are affected to a much greater degree by motion noise due to much lower gyromagnetic constant, e.g. in the ambient magnetic field of 50,000nT the Larmor frequency of the CS-3 is 175,000Hz, which is 82 times larger than 2100Hz, the precession frequency of the proton magnetometer.

Advantages of Self Oscillation

Use of the self-oscillating principle of operation results in the following additional benefits not available from optically pumped magnetometers using locked oscillator principle of operation:

Fast Start-up

If the sensor head is properly oriented inside its active operating zone, the CS-3 will start oscillating shortly after it is turned on. The warm-up time is determined by the time required for the electronically controlled heaters to bring the absorption cell and the cesium lamp to the proper operating temperature.



The warm-up is over in few minutes after a cold start. However, if the operating temperature is already established, it takes only few milliseconds for the magnetometer to start oscillating after a turn on or after an orientation change from a dead zone into the active zone.

In contrast, a locked oscillator magnetometer invariably contains a voltage controlled oscillator (VCO), whose frequency in normal operation is forced (locked) by the control electronics to follow the resonant Larmor frequency.

However, at every start-up, cold or warm, before the locking is acquired, the VCO frequency has to be swept relatively slowly until it comes close enough to the Larmor frequency. Then the locking takes place and the magnetometer becomes operational.

Note that the Larmor frequency is known beforehand only coarsely and consequently this search process takes several seconds. The same search procedure takes place if the lock is lost because of a fast field change or a disturbing AC magnetic field.

Fast Response and Tracking

The response of a self-oscillating magnetometer to the magnetic field changes is extremely fast. It has been experimentally determined that the Larmor frequency precisely changed in response to the step changes of several thousand nT within a Larmor period. Equally, the magnetometer followed sinusoidal field changes of the amplitude of hundreds nT at the rate of several kHz without appreciable lag in response.

In contrast, the rate of ambient field change, which a locked oscillator magnetometer could follow without losing lock, is much smaller. In addition, spurious fields, either AC (50-400Hz) or pulsed, in the range of several hundred nT cause the magnetometer to lose lock.

Low Susceptibility to Electromagnetic Fields

The susceptibility to spurious EM fields depends very much on the principle of operation. Most widely encountered spurious fields originate from the power lines and the airborne geophysical EM systems, and are in the frequency range of 50Hz to several thousand Hz. In general, the susceptibility increases greatly as the frequency of the interfering field approaches the operating (Larmor, proton precession) frequency.

Proton precession magnetometers (including Overhauser) have low susceptibility for two reasons:

- they use induction coils to detected proton precession



- the interfering EM field are normally at the frequencies close to the proton precession frequency.

Neither of above liabilities apply for optically pumped magnetometers because:

- signal detection is optical
- the interfering frequencies are normally far from the Larmor frequency.

In addition, the susceptibility of the self-oscillating magnetometer is low, because its feedback loop is very simple and fast, allowing it to respond with little lag to the fast changing fields.

In contrast, the locked oscillator response is much slower because its control loop frequency bandwidth is limited to few hundred Hz. Furthermore, the feedback control is achieved by monitoring a modulating signal, which frequency is in the range of one hundred Hz, and which detection could be readily upset by the interfering EM fields.

For either of above reasons, the locked oscillator may lose lock and become temporary non-functional for few seconds in presence of a spurious EM field.

Superior Worldwide Orienting Capabilities

The analysis presented in Chapter 3, “Orienting Your CS-3” proves that, contrary to the widely accepted belief, a well designed self-oscillating magnetometer is as easy to orient as the locked oscillator. Even more important, it offers wider safety margins to the boundaries of operating zone, than the locked oscillator.





1

Getting Started

About this manual

Page Numbering

The numbering scheme used consists of two parts: the *chapter number* and *page number*. For example, **3-1** would refer to chapter **3**, page **1**.

For your convenience, each chapter has a thumb-tab on the right-hand side allowing you to quickly locate a chapter of interest. The thumb-tabs are arranged in descending order, with Chapter 1 always starting at the top.



Type Styles

The following typeface conventions will be used throughout the manual.

Convention	Use
<i>Bold Italic</i>	Indicates an action to be taken
<i>Italic</i>	Denotes a new term being introduced
ALL CAPS	Denotes the name of a screen, key or mode (function)



Chapter Layout





This manual is divided into six chapters and four appendices with the information flow detailed in the following table.

Chapter	Description
1. Getting Started	Gives an overview of the manual and describes the instrument's components.
2. Operations	Tells how to set up your CS-3 for a survey, including how to mount and operate the system.
3. Orientation	Gives a detailed theoretical and practical review of the considerations for orienting the instrument to obtain best results.
4. Maintenance	Gives a brief overview of how to maintain and trouble-shoot your system.
5. Reference	Contains the technical specifications, instrument parts list and warranty information.
A.Theory of Operation	Explains the scientific and instrumentation theory for the CS-3 instrument.



Symbols

The following symbols will be used to highlight specific sections of text throughout the manual.

Symbol	Meaning
	Warning: Denotes an important point concerning safety
	Important: Indicates a important topic, particular attention should be paid to this section
	Note: Denotes a point of interest, or information you should read
	Tip: Denotes an interesting hint for smoother operation
	Question: Indicates a relevant question concerning an important topic



Understanding Instrument Basics

The CS-3 Magnetometer Sensor consists of a sensor head and sensor electronics that are interconnected by a cable. This section provides schematics and descriptions for each of these components and their subsystems.

Sensor Head

The sensor head houses electro-optical detection system. All the parts of the sensor head, including the outside plastic housing, are made of carefully screened nonmagnetic materials. The following figure shows a schematic of the sensor head.

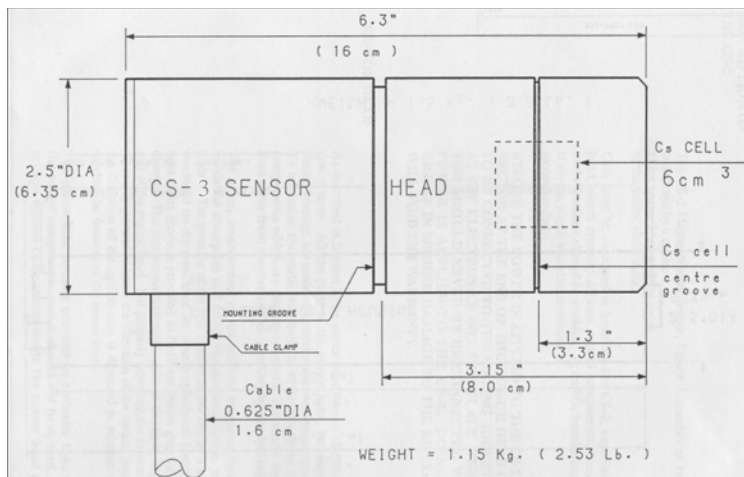

Figure 2 - Schematic of the sensor head





Important:

To minimize the static magnetic interference from the electronic components which are slightly magnetic, the sensor head should be kept away from the electronics assembly by the full cable length.

The actual measurement of the ambient magnetic field takes place inside the absorption cell which has diameter 22mm, and the length 25mm. The position of the cell's centre is marked by a narrow groove, machined on the outside of the plastic cylindrical housing. The adjacent wider groove is provided to facilitate secure grip for the mounting clamps.

The interconnecting cable exits at the right angle on the top end of the sensor head. For properly orienting the sensor head as described in Chapter 3, "Orienting Your CS-3", it is important to know the direction of the optical axis. In Figure 1 on page vii, the direction of the optical axis is depicted in relation to the outside mechanical features of the sensor head.

The sensor head housing provides an air/water tight enclosure for the sensor components, and it should not be opened. In addition, critical optical components inside the sensor head are carefully aligned in order to minimize the orientation errors, and opening the sensor head by unqualified people may upset the alignment.



Sensor Electronics

The sensor electronics are housed in a cylindrical container as shown in the following schematic.

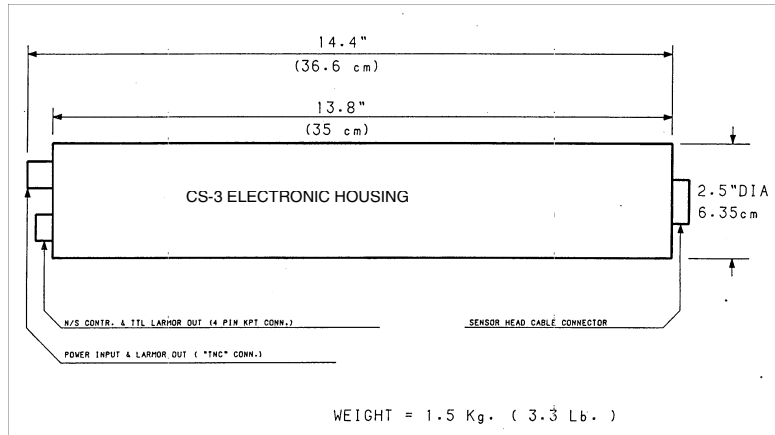

Figure 3 - Schematic of the electronics housing

The electronics consist of three major subsystems:

- Larmor amplifier
- Lamp and absorption cell heaters
- RF lamp exciter

The RF exciter generates few watts of RF power at the frequency of about 165MHz. In order to keep the radiated electromagnetic interference low, the exciter is located inside a metallic enclosure. In addition, all the sensor electronic systems are enclosed inside a cylindrical, metal box.

Electronic Housing

Internally, the sensor electronic housing is connected to the negative line of the input supply voltage. If the negative side of the power supply, which provides the power for the CS-3, is grounded to the frame of the vehicle, and if the electronic box of the CS-3 makes an electrical contact to the same frame, then the return current could flow partially through the frame instead of being confined to the return line inside the supply cable.



The stray magnetic field created by this current could corrupt the measurement of the ambient field. To prevent that happening, the outside of the electronics box is covered with a thin, plastic insulating sleeve.



Important:

Please, make sure that this plastic sleeve is not damaged to such an extent that the metal part of the CS-3 electronics housing is making contact to a metal part of the airplane or vehicle frame.

The sensor head connector is mounted on one side panel of the electronic box. On the opposite side, following components are mounted on the control panel, see Figure 4.

Hemisphere Control Switch

The hemisphere control switch is a four-position rotary switch as shown below. Please note that depending upon the version of your Cs-3, you will have either version.

OLD VERSION

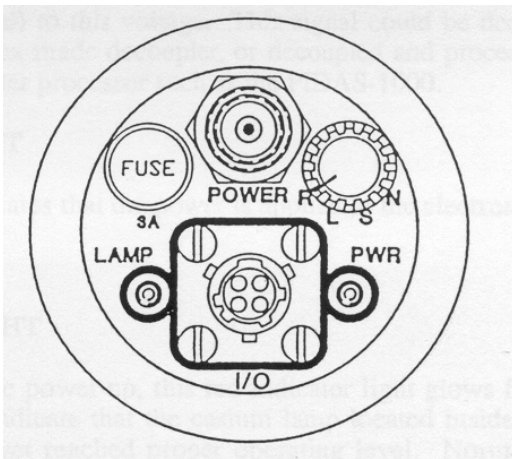

NEW VERSION

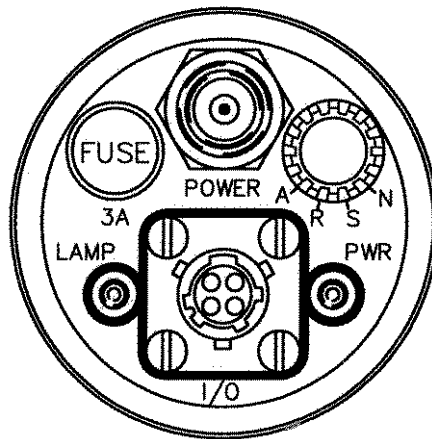

Figure 4 - Schematic of the hemisphere control switch



Old version

The switch settings perform the following functions:

N - Manually sets the CS-3 to operate in northern operating hemisphere.

S - Manually sets the CS-3 to operate in southern operating hemisphere.

L - Local setting allows the operation of the CS-3 to be controlled by the TTL voltage level at the pin D of the four pin connector (pin A is ground): open circuited or high level voltage for operation in southern hemisphere, low level voltage or short connected to pin A for operation in northern operating hemisphere.

R - (JP3 - OFF, JP2 - ON). Remote setting allows the operation of the CS-3 to be controlled remotely by superimposing on the supply voltage an 80Hz sine signal. In the absence of the signal, the CS-3 is set to operate in the northern hemisphere.

R - (JP3 - ON, JP2 - OFF). Automatic hemisphere switch.



Note:

JP2 and JP3 refer to jumpers on the Larmor board.

New version

The switch settings perform the following functions:

N - Manually sets the CS-3 to operate in northern operating hemisphere.

S - Manually sets the CS-3 to operate in southern operating hemisphere.

R - Remote setting allows the operation of the CS-3 to be controlled by the TTL voltage level at the pin D of the four pin connector (pin A is ground): open circuited or high level voltage for operation in southern hemisphere, low level voltage or short connected to pin A for operation in northern operating hemisphere.

A - Automatic hemisphere switch.

I/O Connector

Four pins of the I/O connector carry following signals:



A - ground level

B - positive input of the supply voltage +24 to 35 V; this input is connected in parallel to the centre pin of the coaxial TNC power connector on the same panel

C - Larmor output signal, TTL compatible square voltage signal at Larmor frequency

D - TTL compatible input: high level or open for operation in the southern operating hemisphere, low level or connected to pin A for operation in the northern hemisphere. This input is effective only if the Hemisphere Control switch is in the Remote (R) position.



2

Operating the CS-3 in the Field

By now you have familiarized yourself with your CS-3. This chapter reviews the basic steps required to carry out a survey. They include the following:

- setting up the CS-3
- mounting the CS-3
- powering up
- obtaining the Larmor frequency
- setting the operating hemisphere
- operating in the presence of spurious magnetic fields



Setting Up the CS-3

The basic procedure for setting up the CS-3 is as follows:

- mount the sensor in the vehicle according to the mounting instructions (see below)
- connect the sensor head to the electronics via the supplied cable



Note:

To minimize the static magnetic interference from the electronic components which are slightly magnetic, the sensor head should be kept away from the electronics assembly by the full cable length. If the electronics is kept at 3 meters away from the sensor head, its magnetic signature is less than 0.1nT.

- make sure that you have between 24 and 35V of power to the device
- connect the CS-3 to the power connector (i.e. link to your power supply, data acquisition unit or coupler)
- turn on the power



Warning:

BEFORE THE POWER IS APPLIED TO THE CS-3, THE CONNECTOR AT THE END OF THE SENSOR HEAD CABLE HAS TO BE CONNECTED TO THE MATING SOCKET LOCATED AT THE ELECTRONICS BOX SIDE PLATE. THIS CONNECTOR SHOULD NEVER BE DISCONNECTED WHILE THE POWER IS APPLIED TO THE CS-3. DOING SO WILL RESULT IN SERIOUS DAMAGE TO THE RF EXCITER AND WILL VOID THE WARRANTY.

- let the unit warm up for a designated warm up period to enable the lamp and heaters to stabilize (i.e. stabilize the optics)

The remainder of this chapter provides more details that will help you with installation and start-up.



Mounting the CS-3

The quality of data depends greatly on the quality of the installation. Our advice is to obtain the services of a highly skilled systems engineer for the installation of all magnetometer sensors and associated survey instrumentation. There are numerous factors related to aircraft, instrumentation and custom modifications that may be required to achieve a successful installation.

In general, when mounting a high sensitivity sensor such as the CS-3, you should consider the following guidelines:

- Secure the sensor so that it is rigid during aircraft motion. The use of a proper gimbal is highly recommended. The gimbal makes changing the orientation easier and also provides a secure base for operating the sensor.
- Keep the sensor as far as possible away from moving surfaces or magnetic inducing objects.
- Screen all hardware used in proximity of the sensor for ferrous contamination.
- Minimize the amount of conductive hardware, such as brass screws and aluminum, as they will introduce a secondary field when they are in motion through the earth field.
- Although the sensor electronics have a minimal magnetic signature, keep the electronics as far away as possible from the sensor.
- Always ensure that the cable between the sensor and electronics is physically secured.
- Do not coil the cable to take up slack. If necessary, all slack should be at the preamplifier electronics end of the installation.
- Always ensure that there is adequate ventilation at both the sensor head and the preamplifier electronics. This is especially critical when operating in hot climates.
- Keep the sensor away from direct exposure to weather elements and keep it clean from debris.
- Ensure that there is adequate static discharge available along the surrounding surfaces of the aircraft installation. In dry conditions, static will build along the flying surfaces and create noticeable “pop” noise in the data during discharges.
- Do not place secondary sensors, such as a fluxgate magnetometer, in very close proximity to the cesium sensor.



Powering Up

The power for the CS-3 should be supplied from a DC supply 24-35V, 2A minimum supply capability. The power can be connected either through either:

- the coaxial TNC connector by a 50 ohm coaxial cable (centre pin positive wire)
- the four pin I/O connector, on pins B (positive wire) and A (negative wire).

The sensor electronics is protected from an accidental polarity reversal on both power inputs.

The green light on the side panel indicates that the power is applied to the sensor electronics. Initially, after the power-up, the red indicator light glows for a short while to indicate that the cesium lamp located inside the sensor has not yet reached proper operating level.

Normally, this indicator light will go off completely indicating that the cesium lamp is radiating sufficient light. At 25°C it takes normally only few seconds for this light to go off. At a low ambient temperature, it may take longer for the lamp exciter to warm up and for the lamp to start to operate properly.

At the beginning of the cold start-up, the power supply current will be highest, approximately 1.5A, as the cell and the lamp heater are operating at the full output capacity. As the cell and the lamp are approaching the required stabilized operating temperature, the supply current will decrease and it will reach steady level which is ambient temperature dependent.

At the 20°C the supply current will be approx. 0.5A, at -40°C it is approx. 0.7A. The warm-up time is less than 5 minutes at 20°C, increasing to less than 15 minutes at -40°C.

Warning:



Make sure that power line voltage is in the specified range and clean without transients. Under voltage will cause interruptions or loss of larmor signal. Over voltage will cause serious permanent damages to your CS-3 and warranty will be void.



Obtaining the Larmor Signal

If the sensor head is properly oriented inside its active operating zone, as described in Chapter 3, “Orienting Your CS-3”, the CS-3 will start oscillating shortly after it is turned on, as soon as the absorption cell and the cesium lamp reach the operating temperature.



Note:

If the operating temperature is already established, it takes only few milliseconds for the magnetometer to start oscillating after a warm power-up or after an orientation change from a dead zone into the active zone.

The frequency of oscillation is called the Larmor frequency. The Larmor frequency is proportional to the magnitude of the ambient magnetic field. The constant of proportionality, which relates the magnitude of the ambient magnetic field to the Larmor frequency, is known as the gyromagnetic constant and for the cesium 133 it equals 3.498577Hz/nT.

The amplitude of the output signal of the CS-3 is kept nearly constant (+/-15% variation is due to the transformer frequency characteristic) by electronic means for magnetometer orientations inside the active zone, in spite of:

- the amplitude changes of the light modulation (original Larmor signal) with the magnetometer orientation and
- the amplitude versus frequency dependence of the Larmor amplifier electronics.

Output Signals

The output signals at the Larmor frequency are available in two formats:

- square wave signal with TTL/CMOS logical levels is available at the I/O connector, pin C, with the ground at pin A. Fast transitions of the square wave make this output much less susceptible than the sinewave output to the system noises like ground line noise. The output driving capability of this output restricts the maximum cable length of the RG-58 coaxial cable to 8 meters. An external line driver is required if the signal is to be transmitted over the longer distance.



- sinewave Larmor signal is transformer coupled inside the sensor electronics box on to the D.C. power supply line. This is done in a similar way as in the older models of Varian and Scintrex cesium vapor magnetometers. The only difference that the output amplitude of the CS-3 is electronically stabilized to be independent of the sensor orientation or slightly dependent of the Larmor frequency over the range of 50-350kHz. This additional feature will prevent the sensitivity of the magnetometer to deteriorate more than necessary in presence of the power supply noise. The power supply noise affects more the signal with the lower amplitude.

Couplers, Processors and Power Supplies

In older magnetometers the output amplitude was varying as much as 10:1. The CS-3 magnetometer could easily replace, as far as the power and signal conditioning is concerned, the older models without any changes to the existing equipment such as sensor couplers, magnetometer processors, power supplies.

The only incompatibility is in the control of the operating hemisphere, as it will be explained in the next section. The Larmor signal coupled on the coaxial power cable could be transmitted to the processor (decoupler) over the distance of up 100 meters before it is decoupled by a transformer.

Many of modern magnetometer processors, such as Scintrex MEP series of processors, incorporate the power and signal conditioning circuits such as the regulated power supply and the sensor decoupler. One has to just connect the coaxial power cable to the appropriate power output connector and the installation is complete. The supply current is measured and displayed, as well.

For more detailed information, please, refer to the specific processor operating manual. The MEP series of processors obsoletes the older generation of Scintrex self standing sensor couplers such as VIW2340A1 or VIW2340D4, but they still could be used in existing installations to decouple the Larmor signal from the CS-3.



Setting the Operating Hemisphere

It has been briefly explained why the operation of the CS-3 is divided in two operating hemispheres in Chapter 1, “Getting Started with the CS-3”. Chapter 3, “Orienting Your CS-3” defines the operating hemispheres in more detail, and provides instructions on how to orient the sensor head.

Here, we explain how the operator can control the setting of the operating hemisphere. The Hemisphere Control switch is used to select the mode of control. FOUR modes of control of the operating hemisphere setting are available:

Manual Control

Two positions of the Hemisphere Control switch are used for the manual control:

- in position "N" the CS-3 is set manually to operate in the northern operating hemisphere.
- in position "S" the CS-3 is set manually to operate in the southern operating hemisphere.

Electronic Control "R"

In the position "R" of the Hemisphere switch, the setting of the operating hemisphere is actuated by the TTL compatible control voltage level at the pin D of the four pin I/O connector: open circuited or high level voltage for setting the operation in southern hemisphere, low level voltage or short connection to the pin A for operation in northern operating hemisphere.

The control voltage could be supplied to the connector pins D and A through a coaxial cable or a pair of twisted wires. The length of the cable or the wires is not critical, as the control voltage is D.C. signal.

“A” - Automatic Hemisphere Switch

In the position “A” of the hemisphere switch, the CS-3 is operating in automatic hemisphere switching mode.



Summary

If the CS-3 is properly oriented inside the active zone, defined by equations (1) and (2) in Chapter 3, “Orienting Your CS-3”, and the operating hemisphere is not set properly either of following will happen:

- There will be no Larmor signal at the output. By setting the operation to the proper operating hemisphere, the Larmor signal will appear.
- There will be signal at the output, but not at the Larmor frequency. The false magnetic field reading will be higher than the true reading, obtained when the operating hemisphere setting is correct (about 60nT higher if the ambient field is 60,000nT). In addition, it will be much noisier.

The reason for this is the existence of another resonant line, smaller in amplitude and opposite in phase from the desired resonant signal. The self-oscillation based on this signal can take place if the operating hemisphere is wrongly selected. By setting the operation to the proper operating hemisphere, the true, lower value and less noisier, magnetic field reading will be obtained.

The described alternative modes of controlling the operating hemisphere of the CS-3 are incompatible with the optional electronic control used in older models of Varian and Scintrex magnetometers.

The reversing of the magnetometer power supply polarity, used in these older magnetometer models, had certain disadvantages and it was abandoned in the CS-3. It is not difficult to change the existing installations by rewiring the switch used for the power supply reversal and to make it perform level control required by the electronic control mode "R", as described in this section, or by automatic hemisphere switching.



Operating in the Presence of Spurious Magnetic Fields

It is not uncommon for magnetometers to be required to operate in presence of higher magnitude (over 50nT) alternating magnetic fields. These fields are present close to the power lines, and in the survey airplanes equipped with EM transmitters.

Before it is explained how the AC magnetic fields could upset the operation of a real magnetometer, specifically the CS-3, it is worth mentioning that readings of an ideal scalar magnetometer can be affected by an AC field. The alternating field adds vectorially to the D.C. field to be measured.

Due to the nonlinearity of the vector addition (squaring and taking square root) one observes an error. If the AC field $\mathbf{b}(\cos\omega t)$ has a component $b_p(\cos\omega t)$ at right angle to the D.C. field B , one measures effectively the mean value equal to $B_e = B[1 + (b_p/2B)^2]$.

For gaining more insight, the effective mean value is tabled for $B=50000\text{nT}$ and several values of b_p :

$b_p[\text{nT}]$	0	100	200	500	10000
$B_e[\text{nT}]$	50000.00	50000.05	50000.20	50001.25	50005.00

If the magnitude or the orientation of the AC field changes, the effective mean value will change as well.

The CS-3, as explained the “Foreword” of this manual, is much less sensitive to the spurious AC fields than either the proton precession (including Overhauser) magnetometers or the locked oscillator optically pumped magnetometers.

In the CS-3, the spurious AC field affects the precession of the magnetic moment similarly to the H_1 field. More information is provided in Appendix A, “Theory of Operation”. If the AC field is large enough it will provoke considerable light modulation at its own frequency. Further away the spurious field frequency is from the Larmor frequency larger magnitude is required to cause trouble. If this light modulation becomes comparable in amplitude to the normal modulation induced by the feedback field H_1 , the operation of the CS-3 may be seriously affected.



Operating the CS-3 in the Field

It is important to mention that the disturbing effect is reduced, if the direction of the spurious AC field is perpendicular to the sensor optical axis. It has been experimentally determined that in this case the tested magnetometer operated satisfactory in presence of the disturbing field with magnitude 3500nT peak at the frequency 3kHz.

The operating range of the tumble angle, in the plane perpendicular to the direction of the spurious field, was reduced from 10°-85° (without the AC field) to 25°-65° (with the AC field).



3

Orienting Your CS-3

An ideal magnetometer placed in a constant field should produce a constant frequency. A real optically pumped magnetometer, regardless of which element it uses for its operation (cesium, rubidium, potassium or helium), and regardless of which principle of operation it employs (self oscillating, locked oscillator), produces a frequency which varies because:

- the unavoidable sensor noise makes the frequency jitter around the correct frequency
- the output frequency is somewhat dependent on the magnetometer orientation

The later dependency gives rise to the so-called *heading error*. Both, the magnetometer noise and the heading error, are low due to proper design and careful alignment of the magnetometer. Precautions should be taken that they are sustained low by properly orienting the magnetometer sensor inside the operating active zone.

The purpose of this section is to recommend how to achieve the proper orientation without restricting established survey practices.



Understanding the Active Zone of the CS-3

The sensor head assembly has a so called optical axis. The angle between the positive direction of the optical axis and the direction of the magnetic field, H_o , is called the *tumble angle*, φ .

As explained in Appendix A, “Theory of Operation”, there is no Larmor signal generated in a self-oscillating magnetometer such as the CS-3 if the optical axis is parallel to the magnetic field (the polar orientation, $\varphi=0^\circ$ or $\varphi=180^\circ$) or perpendicular to the field (the equatorial orientation, $\varphi=90^\circ$).

The optical signal amplitude increases quite rapidly outside those two orientations, and it has a broad maximum around $\varphi=40^\circ$ or $\varphi=140^\circ$.



Note:

The Larmor signal amplitude generated inside the sensor head is not to be confused with the signal output of the CS-3 available either inside the electronics assembly or at the output of the PDAS-1000A Power Signal Coupler. The Larmor signal amplitude at these outputs is electronically kept constant, in spite of the variations of Larmor signal itself and the amplitude variation of the detection and amplification circuits.

Experimental results confirm that the CS-3 will perform satisfactorily when the angle φ is from:

$$10^\circ < \varphi < 85^\circ \tag{1}$$

and from

$$95^\circ < \varphi < 170^\circ \tag{2}$$

Equation (1) covers the magnetometer's active zone in the northern operating hemisphere. This active zone is depicted in Figure A-2. The measured magnetic field could be anywhere inside the space bound by the northern polar dead zone cone and the equatorial dead zone "disk".

Note, that the polar sensor orientation occurs when the sensor optical axis is parallel with the ambient magnetic field. In the northern polar orientation the magnetic field and the sensor optical axis point in the same direction ($\varphi=0^\circ$),



in the southern polar orientation they point in the opposite directions ($\alpha=180^\circ$). The equatorial orientation occurs when the optical axis is perpendicular to the ambient magnetic field ($\alpha=90^\circ$).

Equation (2) covers the magnetometer's active zone in the southern operating hemisphere. This active zone is depicted in Figure A-3 on page A-4. The magnetic field could be anywhere inside the space bound by the southern polar dead zone and the equatorial dead zone.

The Earth's magnetic field vector is pointing into the ground in the Earth's northern magnetic hemisphere, and out from the ground in the Earth's southern magnetic hemisphere. It is parallel with the ground at the Earth's magnetic equator. Note, that neither the Earth's geographic and magnetic poles nor the equators exactly coincide, as it can be seen in Figure 5.

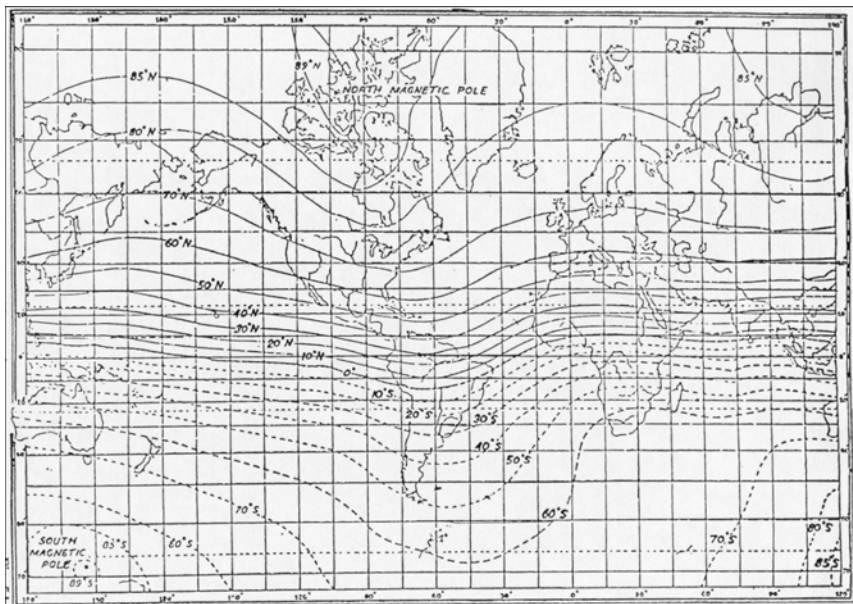

Figure 5 - Earth magnetic field inclination angle (degrees)

The Hemisphere switch located on the CS-3 control panel allows setting of the electronics for the proper operation in either northern or southern operating hemisphere. **The operating hemisphere setting could be either manually controlled locally or electronically remotely controlled**, as explained in Chapter 2, “Operating the CS-3 in the Field” and the topic “Operating in the Presence of Spurious Magnetic Fields” on page 2-9.



Inside its operating range the CS-3 performance is acceptable, in regard to measurement noise and heading errors. The measurement noise starts to increase appreciably only when the magnetometer orientation comes close to the boundary of the operating range given by equations (1) and (2). It is about three times larger at the boundary of the operating range than it is at a broad minimum centered around the middle of the operating zone. It is about twice as large 5° away from the boundary of the operating zone.

Equally, the heading errors are low inside most of the operating zone, and increase somewhat faster close to the polar dead zones, as shown on the typical plot of the tumble heading error curve, Figure 6. Note that the actual dead zones are very narrow: the polar and equatorial dead zones are approximately 8° and 4° respectively. The actual operating zone is several degrees larger than indicated by relationships (1) and (2).

The records in Figure 6a and b were made during the alignment of a CS-3 sensor at the Scintrex test facility 50 km north of Metro Toronto. The test facility is constructed to have low magnetic signature and to be away from man made magnetic interferences. The test facility consists of two buildings separated 35 meters apart and well away from a rural road. The instrument building contains all the test equipment and in the test building there are only the magnetometer to be aligned and the reference magnetometer.

The test building is constructed of wood, fastened by aluminum nails. The magnetometer sensor under test is mounted on a gimbal system, which is remotely operated from the instrument building. The gimbal system facilitates the rotation of the sensor around:

- the axis which passes through the center of the absorption cell and it is perpendicular to both, the sensor optical axis and to the direction of the ambient magnetic field - this arrangement is used for the tumble heading error tests, and around
- the optical sensor axis - this arrangement is used for the spin heading error tests.



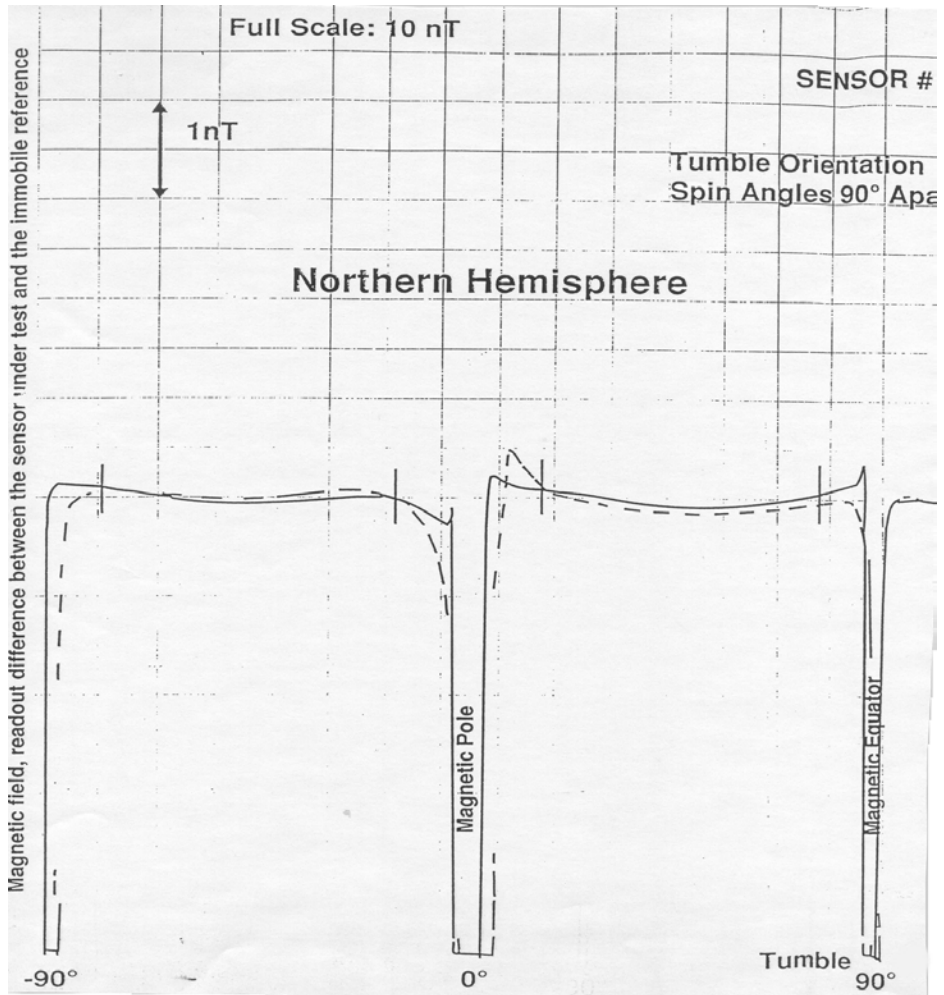

Orientation

Figure 6a - Plot of tumble heading error curve (northern hemisphere). Plot shows magnetic field (readout difference between a specific sensor under test and an immobile reference) against tumble angle.



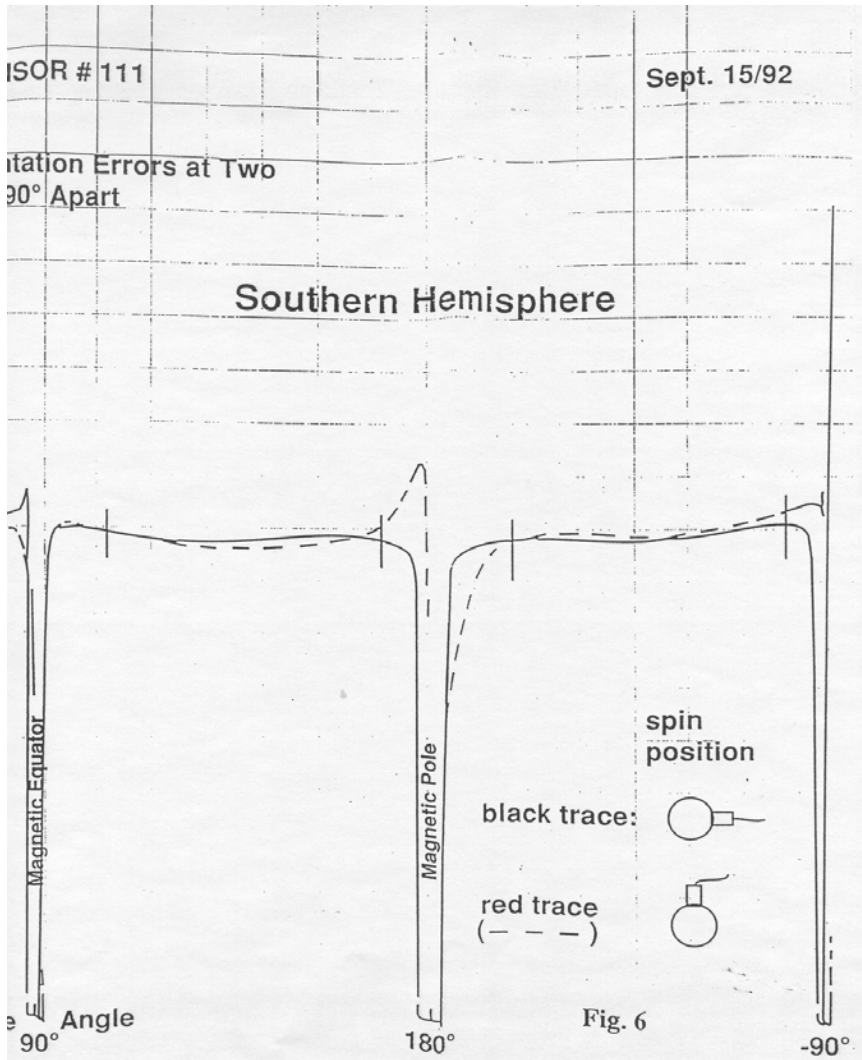

Figure 6b - Plot of tumble heading error curve (southern hemisphere).

Plot shows magnetic field (readout difference between a specific sensor under test and an immobile reference) against tumble angle.



Using a Strapped Down CS-3 for Surveys

Wherever a magnetic survey is conducted, the CS-3 Cesium Magnetometer can be strapped rigidly to a survey vehicle, such as an airplane, a ship or an automobile. It is convenient to use a simple, nonmagnetic gimbal platform made by Scintrex, as this allows the magnetometer sensor to be precisely and quickly oriented in azimuth and inclination.

The vehicle conducts a magnetic survey by moving on the well defined survey grid consisting of parallel survey lines. If the survey lines are oriented in the NW direction, for example, the survey vehicle may travel either in the NW or SE directions shown in Figure 7 on page 3-9.

Several times during a survey day, a tie line may be used as shown in Figure 7. The tie line is generally flown at 90° to the survey line, which would be in our example either in the NE or SW direction. The magnetometer sensor orientation must be selected so that it performs well on the direction parallel or antiparallel to the survey line, and parallel or antiparallel to the tie line, which is perpendicular to the survey line.

Calculating the Tumble Angle

CS-3 sensor orientation is determined by two angles:

- the sensor azimuth, a , defined as the angle in the horizontal plane between the horizontal projection of the sensor optical axis direction and the direction of the magnetic north
- the magnetometer sensor inclination, b , defined as the angle in the vertical plane between the horizontal line and the magnetometer optical axis.
- The ambient magnetic field inclination, g is defined as the angle between the horizontal and the field direction. The Earth's magnetic field inclination is a positive angle in the range from 0° to 90° in the Earth's Northern Magnetic Hemisphere and negative in the Southern Hemisphere. Its dependence on the geographic location is shown in Figure 5 on page 3-3.

For a given sensor orientation and magnetic field inclination, the angle between the sensor and the magnetic field, i.e. the tumble angle, q , can be calculated from the following equation:

$$q = \arccos(\cos a \times \cos b \times \cos g + \sin b \times \sin g) \quad (3)$$



This equation can be used to find out whether the magnetometer sensor is inside its active zones specified by equations (1) and (2). It is a good idea to reduce the operating active zone by the amount of the anticipated aircraft motion. In general, airborne magnetic surveys are conducted in calmer weather to keep the aircraft motion to within 5° in pitch, roll and yaw.

In this case, with the additional allowance we must orient the magnetometer sensor so that the tumble angle, α , satisfies in the northern operating hemisphere the relationship:

$$15^\circ > \alpha > 80^\circ \quad (4)$$

and in the southern operating hemisphere the relationship

$$100^\circ > \alpha > 165^\circ \quad (5)$$

Inside this operating zone the magnetometer noise will increase by about a factor of two from the minimum value at $\alpha=40^\circ$ or $\alpha=140^\circ$, and the heading error will be inside the specified limits of $\pm 0.25\text{nT}$.

As it will be seen in the next section, **orienting the CS-3 is simple: with only two settings one can survey the entire Earth's surface.** However, in order to gain more insight, the tumble angle, equation (3), is evaluated, over the entire range of the magnetic field inclinations, for two sets of sensor azimuths, and five values of sensor inclinations. The results are shown on graphs, Figures 7 to 16.

Tumble angles from 0° to 90° indicate that the magnetometer has to be set for operation in the northern operating hemisphere. Tumble angles from 90° to 180° indicate that the magnetometer has to be set for operation in the southern operating hemisphere. As indicated in Chapter 1, “Getting Started”, the operating hemisphere setting is performed manually or electronically.

In accordance with the equations (4) and (5), the polar dead zones are from 0° to 15° and from 165° to 180°. The equatorial dead zones are from 80° to 100°. The azimuth values in each set differ by 90°, to comply with the requirement that both, the flight lines and the perpendicular tie lines, are flown in two opposite directions.

The sensor inclination should be selected so that the sensor will not be in any of dead zones for either one of these four azimuths and over the range of magnetic field inclinations expected in the surveyed area. Comments on advantages and disadvantages of five representative sensor orientations follow.



Sensor Inclination 90°

From the graph in Figure 8, you can determine the value of the tumble angle (the angle between the magnetic field and the sensor optical axis) for all possible values of the magnetic field inclination. Because the sensor is vertical, the tumble angle is independent of the sensor azimuth (one curve is valid for all azimuths).

The operating range of the magnetic field inclinations, for which the tumble angle is inside the active operating zone, is indicated by horizontal arrows in the graph. The sensor orientation shown in the Figure 7 is very useful because it covers most of the Earth's surface with the exception of polar and equatorial regions.

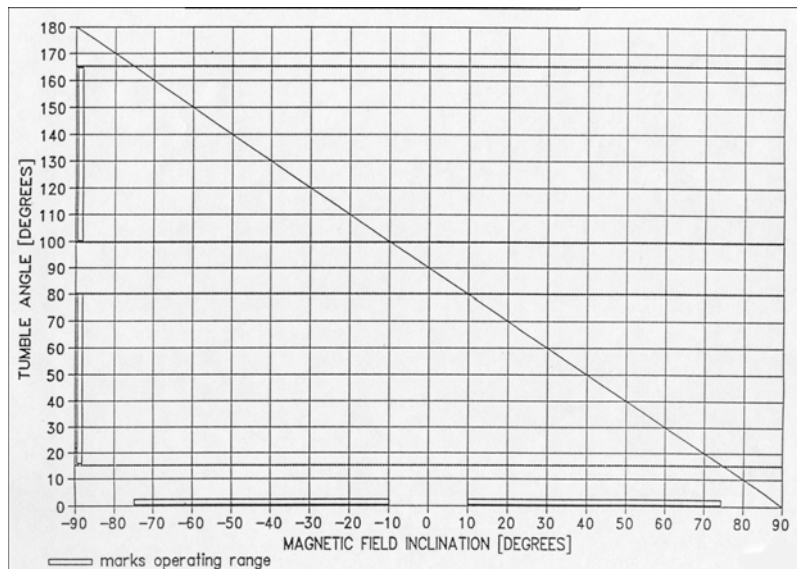

Figure 7 - Plot of tumble angle versus magnetic field inclination. Sensor inclination is 90°. Any sensor azimuth can be used.



Sensor Inclination 67.5°

Sensor azimuth values used in Figure 8 are 0, 90, 180 and 270 degrees. Please note, that the sensor azimuth may differ from the flight direction azimuth, as the sensor axis may have to be set out of the airplane axis. For example, if the line (flight) direction is NE, and the sensor azimuth is to be 90°, then the sensor axis is to be rotated by 45° clockwise from the airplane axis. The particular sensor orientation shown in Figure 8 does not offer any advantages.

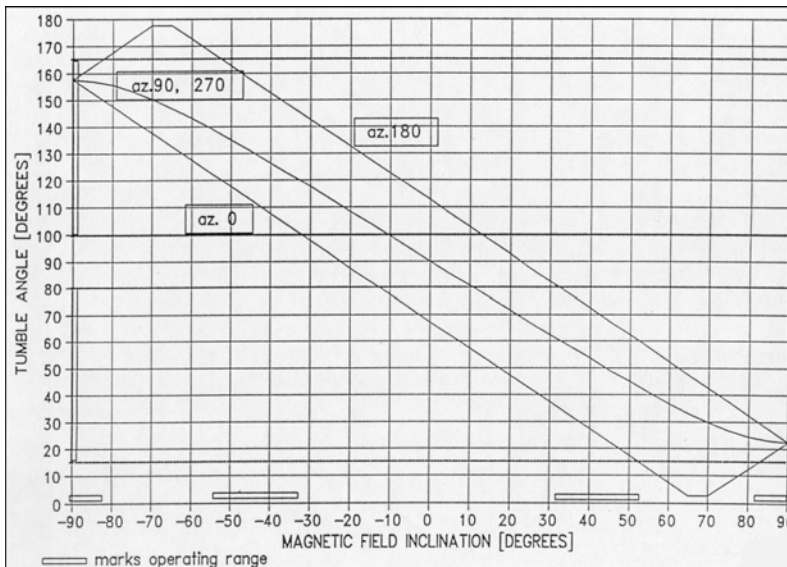

Figure 8 - Plot of tumble angle versus magnetic field inclination. Sensor inclination is 67.5°. Sensor azimuths are 0, 90, 180 and 270 degrees.

A more advantageous orientation is one with the same sensor inclination, but different azimuths, Figure 9. Large areas extending from either pole down to the field inclination of 25° could be surveyed using this orientation. However, the operation is at the edge of the active zone for the magnetic field inclinations around +/-75°.



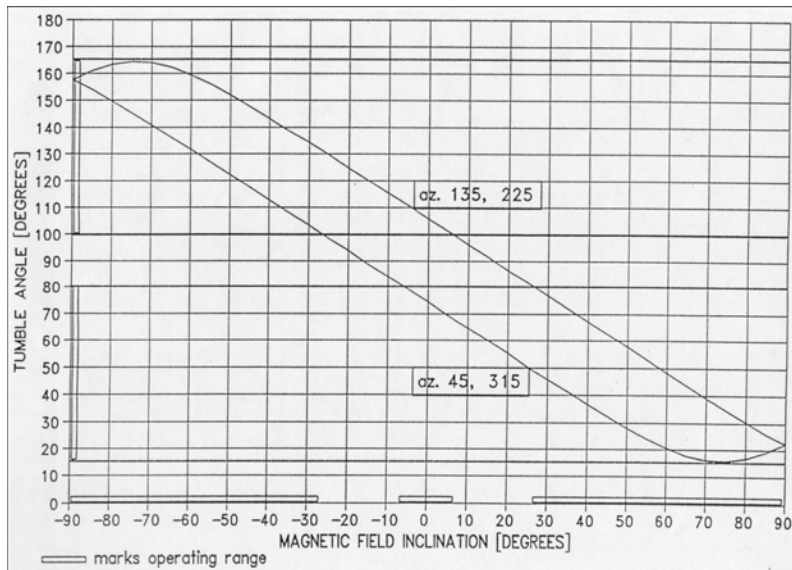

Figure 9 - Plot of tumble angle versus magnetic field inclination. Sensor inclination is 67.5°. Sensor azimuths are 45, 135, 225 and 315 degrees.

Sensor Inclination 47.5°

Tumble angles for the sensor azimuths parallel or perpendicular to the magnetic field direction could be determined from the graph in Figure 10.

This orientation could be used in surveying polar regions. If the azimuth of 90° and 270° are used for flying normal survey lines, the tumble angle is same for both up-the-line and down-the-line flying, and it is well inside the active zone. The sensor orientation shown in Figure 11 offers the advantage of use for surveys in either polar or equatorial regions.



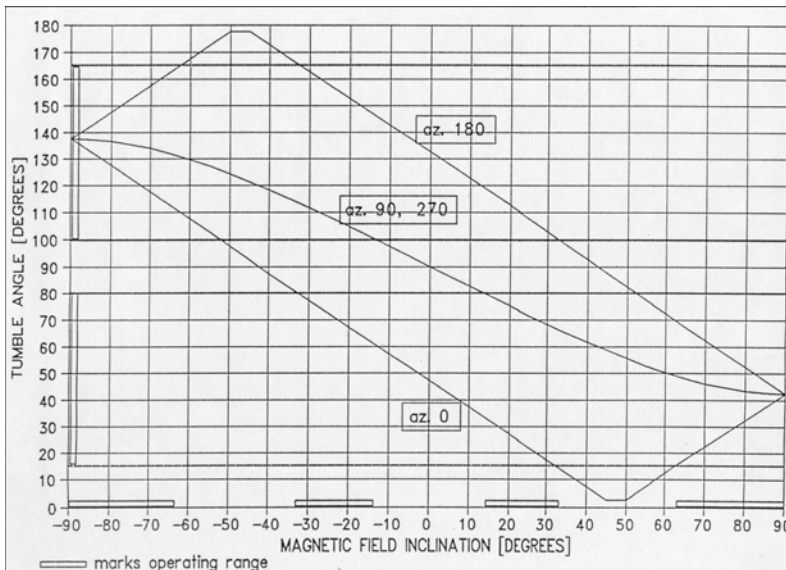

Figure 10 - Plot of tumble angle versus magnetic field inclination. Sensor inclination is 47.5°. Sensor azimuths are 0, 90, 180 and 270 degrees.

Please note, that, when flying in equatorial regions, the sensor operating hemisphere has to be changed from north to south when the flight direction, on either normal or tie survey lines, is changed. The same applies for any other orientation used for surveying in equatorial magnetic field regions.



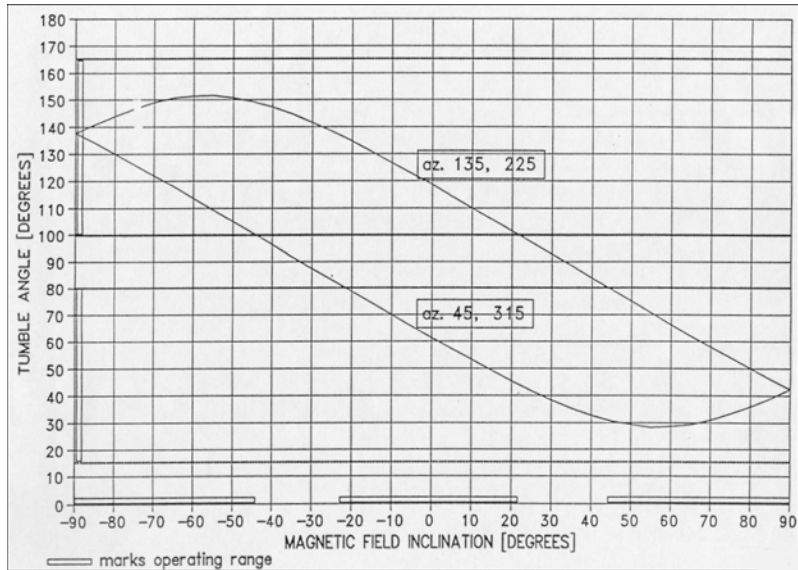

Figure 11 - Plot of tumble angle versus magnetic field inclination. Sensor inclination is 47.5° . Sensor azimuths are 45, 135, 225 and 315 degrees.

For completeness, the orientation with azimuths between those shown in Figures 10 and 11 is shown in Figure 12. As it can be seen, it does not offer any additional advantages.



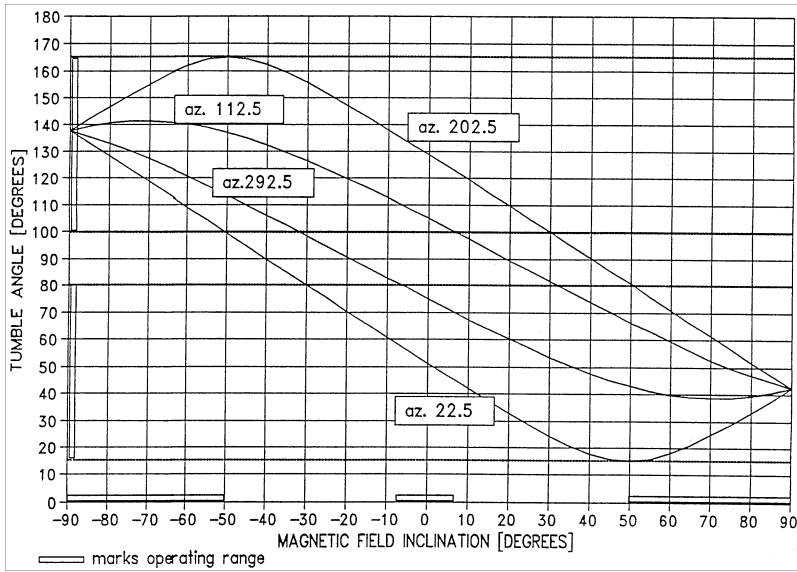

Figure 12 - Plot of tumble angle versus magnetic field inclination. Sensor inclination is 47.5°. Sensor azimuths are 23, 113, 203 and 293 degrees.



Sensor Inclination 22.5°

The orientation shown in Figure 13 does not offer any advantages.

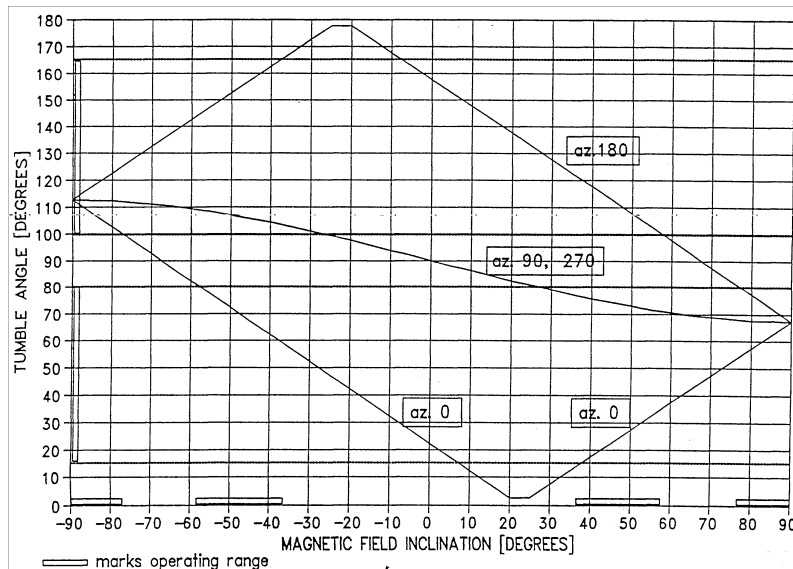

Figure 13 - Plot of tumble angle versus magnetic field inclination. Sensor inclination is 22.5°. Sensor azimuths are 0, 90, 180 and 270 degrees.

The orientation in Figure 14 offers, in comparison with the orientation in Figure 11, an extension of surveying into regions well away from the magnetic equator at the expense of reduction in the polar regions.



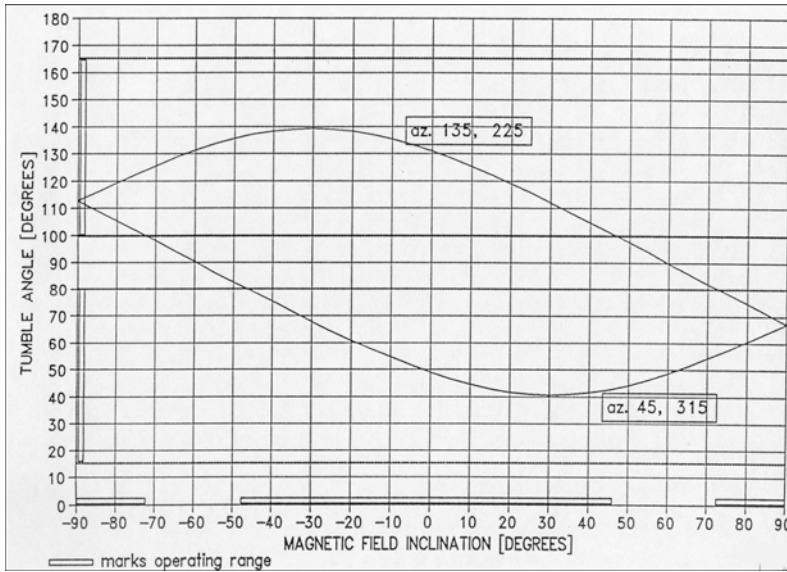

Figure 14 - Plot of tumble angle versus magnetic field inclination. Sensor inclination is 22.5°. Sensor azimuths are 45, 135, 225 and 315 degrees.



Sensor Inclination 0°

The orientation in Figure 15 is not acceptable, as the tie lines are in dead zones.

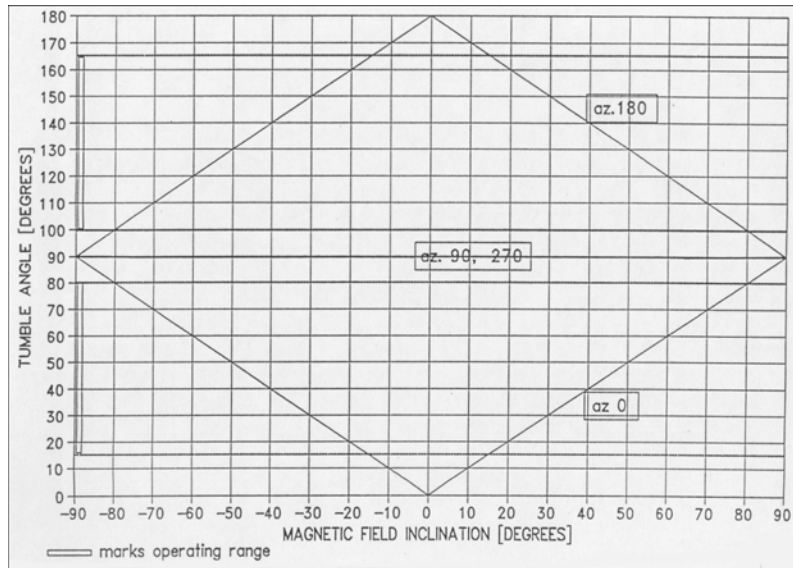

Figure 15 - Plot of tumble angle versus magnetic field inclination. Sensor inclination is 0°. Sensor azimuths are 0, 90, 180 and 270 degrees.

The orientation shown in Figure 16 has the advantage of covering the entire Earth except the polar regions. For large area, up to the field inclination of $\pm 45^\circ$, the sensor operates far from the dead zones, but the sensor operating hemisphere has to be changed when the flight direction is reversed.



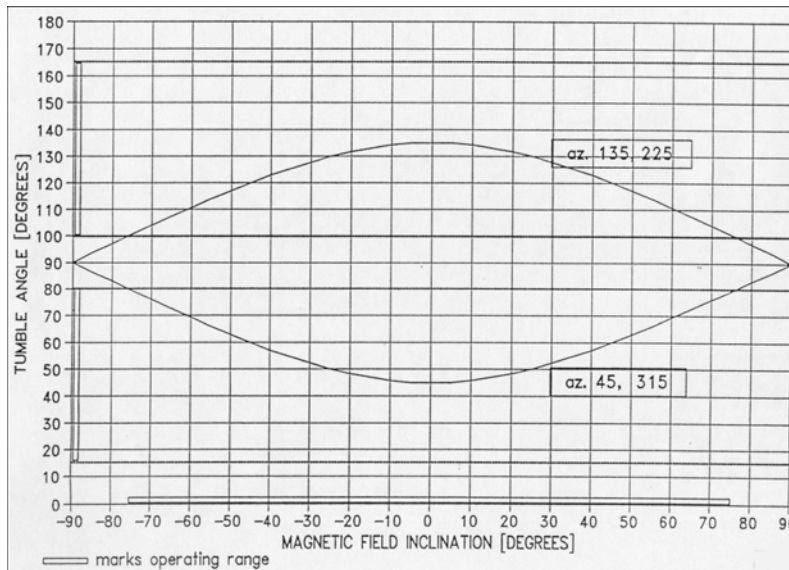

Figure 16 - Plot of tumble angle versus magnetic field inclination. Sensor inclination is 0°. Sensor azimuths are 45, 135, 225 and 315 degrees.

Recommended Survey Orientations

Only two orientations are sufficient for surveying along two sets of perpendicular lines over the entire Earth's surface:

1. The orientation in Figure 11, with the sensor inclination 45° and azimuths 45, 135, 225, 315 degrees, for polar and equatorial regions, and
2. The orientation in Figure 7 on page 3-9 with sensor inclination 90 degrees, for the regions between polar and equatorial regions. These orientations provide enough overlap at both ends: regions with field inclinations N/S from 53° to 75° and inclinations N/S from 10° to 22° could be surveyed by either sensor orientation setting 1) or 2).



In the overlap regions the tumble angle comes close to boundary of the dead zones. For a larger safety margin following alternate orientation is strongly recommended:

3. The operation around the magnetic equator, extending well into the regions with the magnetic field inclinations up to 45° , could be covered with the sensor inclination 0° and azimuths 45, 135, 225, 315 degrees (see Figure 17).

If the above three orientations are used in both Earth's magnetic hemispheres as follows:

- the orientation a) for the field inclinations from 60° to 90°
- the orientation b) for the field inclinations from 35° to 60°
- the orientation c) for the field inclinations from 0° to 35°

then:

1. the minimum safety margin to the boundary of the operating range is 14° and it will occur for the field inclination 62°
2. the safety margin less than 15° will occur only for the range of the field inclinations from 60° to 65°
3. the safety margin less than 20° will occur for the range of the field inclinations from 55° to 78° .



Note:

The additional allowance of 5° has been already subtracted from the essential operating range specified by relationships (1) and (2) to arrive to the reduced operating range, relationships (4) and (5) for which the above analysis applies.



Comparison with the Locked Oscillator

Optically pumped magnetometers using the locked oscillator principle of operation exhibit two distinct features as far as the operating range is concerned:

- there is no polar dead zone, only the equatorial dead zone is present
- the magnetometer operates in both magnetic hemispheres of the ambient field without any adjustment.

Modern self-oscillating magnetometers, like the CS-3 have overcome the shortcoming of two operating hemispheres by incorporating an effective electronic control of the operating hemisphere selection.

The asset of having only one dead zone was claimed to be a valuable operational advantage "without orientation problems associated with self-oscillating alkali vapor magnetometers" (e.g. EG&G brochure for the G-833 Helium Magnetometer). The following rigorous analysis will prove that the CS-3 has superior orienting capabilities.

The operating range of the locked oscillator extends 65° from the polar orientations according to the relationships:

$$0^\circ < \alpha < 65^\circ \tag{4}$$

and from

$$115^\circ < \alpha < 180^\circ \tag{5}$$

It has been experimentally determined by impartial evaluators that inside this operating zone the magnetometer noise will increase by about a factor of three from the minimum value at $\alpha=0^\circ$ or $\alpha=180^\circ$. Passed this range, noise increases rapidly, e.g. at 70° from the polar orientation the noise is 7-8 times larger than in the polar orientation.

The graphs shown in Figures 7 to 16 apply for the locked oscillator as well while taking into the account the operating range specified by relationship (4) and (5).



Only two orientations are useful and they are sufficient for surveying along two sets of perpendicular lines over the entire Earth's surface:

1. the orientation in Figure 7, with sensor inclination 90 degrees, for the ambient field inclinations from 25° to 90°.
2. the operation around the magnetic equator, extending well into the regions with the magnetic field inclinations up to 55°, is covered with the sensor inclination 0° and azimuths 45, 135, 225, 315 degrees, Figure 16.

If the above orientations are used in both Earth's magnetic hemispheres as follows:

- the orientation 1) for the field inclinations from 35° to 90°
- the orientation 2) for the field inclinations from 0° to 35°

then:

- i) the minimum safety margin to the boundary of the operating range is 10° and it will occur for the field inclination 35°
 - ii) the safety margin less than 15° will occur only for the range of the field inclinations from 25° to 40°
 - iii) the safety margin less than 20° will occur for the range of the field inclinations from 0° to 45°.
- By comparing the criteria i) to iii) above with the same criteria for the CS-3, one can see that the CS-3 offers superior worldwide orienting capabilities.





4

Maintaining Your CS-3 and Trouble-shooting

No maintenance is required. Both, the sensor head and the sensor electronics are enclosed in sealed, splashproof housings.



Important:

Care must be exercised in handling the CS-3, especially the sensor head, which contains delicate optical components. Excessive shocks and vibrations should be avoided.



Warning:

BEFORE THE POWER IS APPLIED TO THE CS-3, THE CONNECTOR AT THE END OF THE SENSOR HEAD CABLE HAS TO BE CONNECTED TO THE MATING SOCKET LOCATED AT THE ELECTRONICS BOX SIDE PLATE. THIS CONNECTOR SHOULD NEVER BE DISCONNECTED WHILE THE POWER IS APPLIED TO THE CS-3. DOING SO WILL RESULT IN SERIOUS DAMAGE TO THE RF EXCITER AND WILL VOID THE WARRANTY.



Trouble-shooting

Despite the fact that your CS-3 is a very reliable instrument, there can be two circumstances where problems may occur. The following table lists some of these problems and their attempted solution. However, please do not hesitate to contact your nearest Scintrex office. See “Warranty and Repair” on page 5-3 for the office nearest you.

Problem	Possible cause	Possible solution
No Larmor signal output	The indication that the CS-3 is receiving power is glowing of the green light. If the light is not glowing, and the power is supplied, then the fuse may be blown.	Check that power is supplied by measuring the voltage at either the I/O connector (pin B positive, pin A negative) or the power TNC coaxial connector (center positive), and then replace the fuse by undoing the fuse cover. The fuse used is Littlefuse type Micro 273 003, 125V AC/DC, 3A.
	The power is not supplied to the sensor electronics.	Check power supply.
	Power supply as measured at points indicated above is not in the range of 24V to 35V DC.	Check power supply. Note, a lower supply voltage is insufficient for proper operation, while a higher supply voltage will result in excessive dissipation of the internal voltage regulators, and may cause permanent damage.
	Current supply not in range.	The supply current after 15 minutes warm-up is in the range 0.5 A (ambient temperature close to 50°C) to 0.8A (ambient temperature close to -40°C).
	Sensor head oriented in the active zone.	Refer to the Orienting the CS-3 chapter.
	Larmor output (readings) are noisy.	Possible conditions as noted for no Larmor signal output.



	There are large spurious AC fields present.	Check for possible sources of local AC fields.
	Excessive field gradients across sensor head.	Check for possible sources of gradients.
	Ambient magnetic noise is low.	Check Power supply and Orientation.

If all of the above conditions are met and Larmor output continues to be either not present or noisy, ship back the CS-3 to Scintrex for repair.





5

Reference Information

CS-3 Technical Specifications

Measurement Range	15,000nT to 100,000nT
Orientation Range	
Northern Operating Hemisphere	Sensor optical head axis 10° to 85° to the ambient field direction
Southern Operating Hemisphere	Sensor optical head axis 95° to 170° to the ambient field direction
Heading Error	+/- 0.25nT inside the optical axis to the field direction angle range 15° to 75° and 105° to 165°
Noise Envelope	0.002nT peak-to-peak in 0.01 to 1 Hz bandwidth
Gradient Tolerance	40,000 nT/meter



Reference Information

Outputs	<p>Continuous signals at the Larmor frequency which is proportional to the magnetic field (proportionality constant 3.498577 Hz/nT)</p> <p>Squarewave signal at the I/O connector TTL, CMOS compatible</p> <p>Sinewave signal amplitude modulated on the power supply voltage</p>
Information Bandwidth	Limited by the magnetometer processor used
Operating Temperature	-40°C to +50°C
Humidity	Up to 100% splashproof
Supply Voltage	24 to 35 Volts DC
Supply Current	Approximately 1.5A at start-up, decreasing to 0.5A at 20°C, larger at lower temperatures
Power Consumption	15W at 20°C, more at lower temperature or during warm-up
Warm-up Time	Approximately 15 minutes at -40°C
Control of the Operating Hemisphere	<ul style="list-style-type: none"> • Automatic • Manual switch control • Electronic control actuated by control voltage level (TTL/CMOS) at the I/O connector Sensor Head to Electronics Interconnecting Cable (standard length 3m and optional 1 to 10 m) with connector at the sensor electronics side. Signature of electronics less than 0.1nT in any orientation at 3m away from the sensor head
Sensor Head	Diameter: 63mm (2.5”) and Length: 160mm (6.3”)
Weight	1.15 kg (2.6 lb.)
Sensor Electronics	Diameter: 63 mm. (2.5”) and Length: 350 mm (1.8”)
Weight	1.5 kg (3.3 lb.)



Instrument Parts List

CS-3 Standard Accessories

Item Description	SCINTREX Part Number
CS-3 Magnetometer (includes:)	762-010
Case	
Sensor	
Electronic processing unit	

Warranty and Repair

Warranty

All Scintrex equipment, with the exception of consumable items, is warranted against defects in materials and workmanship for a period of one year from the date of shipment from our plant. Should any defects become evident under normal use during the warranty period, Scintrex will make the necessary repairs free of charge.

This warranty does not cover damage due to misuse or accident and may be voided if the instrument console is opened or tampered with by persons not authorized by Scintrex.



Repair

When To Ship the Unit

Please do not ship your instrument for repair until you have communicated the nature of the problem to our Customer Service Department by e-mail, telephone, facsimile or correspondence. Our Customer Service Department may suggest certain simple tests or steps for you to do which may solve your problem without the time and expense involved in shipping the instrument back to Scintrex for repair. If the problem cannot be resolved, our personnel will request that you send the instrument to our plant for the necessary repairs.

Description of the Problem

When you describe the problem, please include the following information:

- the symptoms of the problem,
- how the problem started,
- if the problem is constant, intermittent or repeatable,
- if constant, under what conditions does it occur,
- any printouts demonstrating the problem

Shipping Instructions

No instrument will be accepted for repair unless it is shipped *prepaid*. After repair, it will be returned *collect*, unless other arrangements have been made with Scintrex. Please mention the instrument's serial number in all communications regarding equipment leased or purchased from Scintrex.

Head Office

Instruments within Canada should be shipped to:

SCINTREX Limited

222 Snidercroft Road



Unit #1
Concord, Ontario

L4K 2K1
tel: +1 905 669 2280
fax: +1 905 669 9899
e-mail: service@scintrexltd.com







Theory of Operation

System Overview

As shown below, the CS-3 sensor consists of a sensor head with cable and sensor electronics.

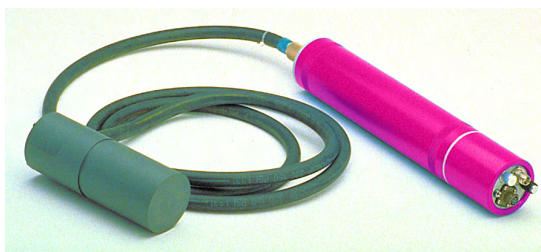

Figure A-1 CS-3 Sensor Head and Electronics

The sensor head has an electrodeless discharge lamp (containing cesium vapor) and absorption cell. Electrical heaters bring the lamp and the cell to optimum operating temperatures with control and driving circuits located in the electronics console. Heating currents are supplied to the sensor head through the interconnecting cable.



When operating, an RF oscillator in the electronics console provides RF power to a lamp exciter in the sensor head and the radio frequency (RF) field produces a corresponding resonant optical radiation (light).

The light radiating from the cesium lamp is collimated by a lens. The light propagates in the direction of the sensor optical axis (as shown in Figure A-1) and passes through an interference filter which selects only the cesium D1 spectral line. The light is subsequently polarized in a split, right/left hand circular polarizer before it is allowed to optically excite cesium vapor in the absorption cell.

The narrow bandwidth resonant light causes momentary alignment (polarization) of the atomic magnetic moments to the direction of the ambient magnetic field. The resonant light "optically pumps" the cesium atoms to a higher energy state. (Note that the polarizing light beam has to be oriented in the general direction of the ambient field to be effective.)

Large numbers of cesium atoms can be polarized by optical pumping and then induced to precess coherently in phase around the ambient field by means of a small magnetic field, H_1 . This small magnetic field is transverse to the ambient field and alternating at the Larmor frequency.

The H_1 field is produced by a coil in the CS-3. The coil is coaxial with the sensor optical axis and wound around the absorption cell. Polarized resonant light perpendicular to the ambient magnetic field detects the precession. This light is alternately more or less absorbed, depending on the instantaneous orientation of the polarization.

In the CS-3, this probing light is the perpendicular component of the resonant light beam. If the modulation of through-the-absorption-cell transmitted light is detected with the photosensitive detector, and the resulting Larmor signal is sufficiently amplified and phase-shifted before being fed back to the H_1 coil, then a closed loop self-oscillating circuit results.

The resonance occurs at the Larmor frequency, which in weak fields, e.g. the Earth's magnetic field, is precisely linear with the field in which the absorption cell is located. For the cesium 133 the proportionality constant (gyromagnetic constant) is 3.498577 Hz per nT.

As indicated, different components of the same resonant light beam perform two functions:

- the component parallel to the ambient field performs the optical pumping
- the perpendicular component detects the coherent precession.



Therefore, no pumping is taking place if the light beam (the optical axis) is perpendicular to the ambient field (the equatorial orientation) and consequently the sensor is not operating. Equally, no light modulation is taking place if the light beam is parallel with the ambient field (the polar orientation) and consequently the sensor is not operating.

The second reason for the sensor not operating in the polar orientation is that the H_1 field, being parallel to the ambient field, can not induce precession of the magnetic polarization.

The plane perpendicular to the ambient field divides the sensor operating zones into two hemispheres - northern and southern operating hemisphere. In the northern operating hemisphere the sensor light beam, which propagates in the direction of the optical axis, Figure A-2, forms an angle from 0° to 90° with the direction of the ambient field. In this hemisphere, the phase shift of the Larmor signal amplifier required for the self-oscillation at the peak of the resonance is -90° .

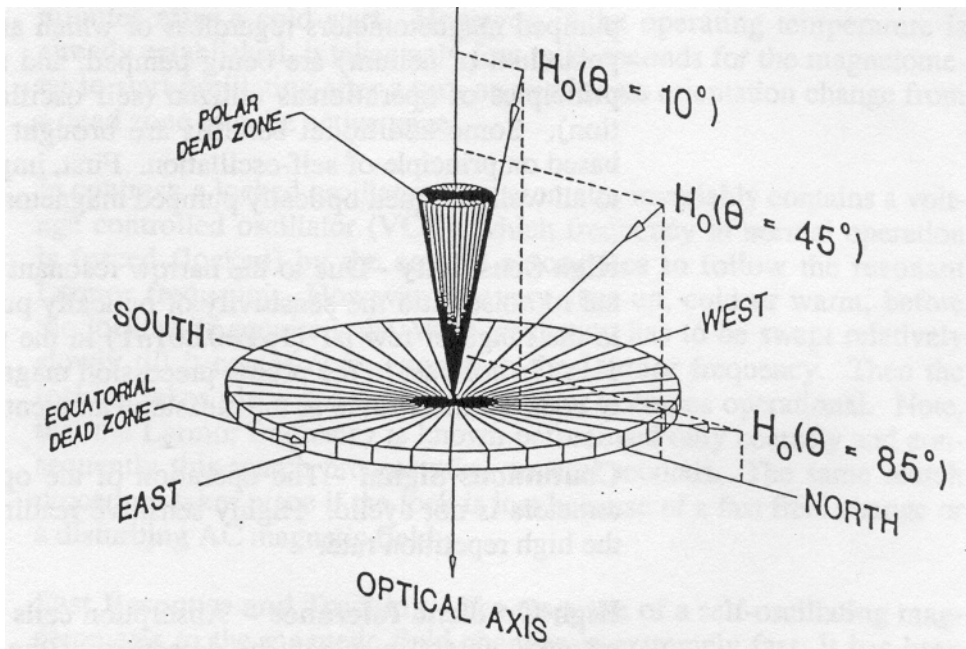

Figure A-2 Northern Operating Hemisphere



In the southern operating hemisphere the light beam forms an angle from 90° to 180° with the ambient field direction, Figure A-3. There, the phase shift of the Larmor signal amplifier required for the self-oscillation at the peak of resonance is $+90^\circ$. Thus the phase change of 180° is required to make the sensor operational when the operating hemisphere is changed. The control of this electronic phase reversal is performed by the hemisphere switch as explained in "Setting the Operating Hemisphere" on page 2-7.

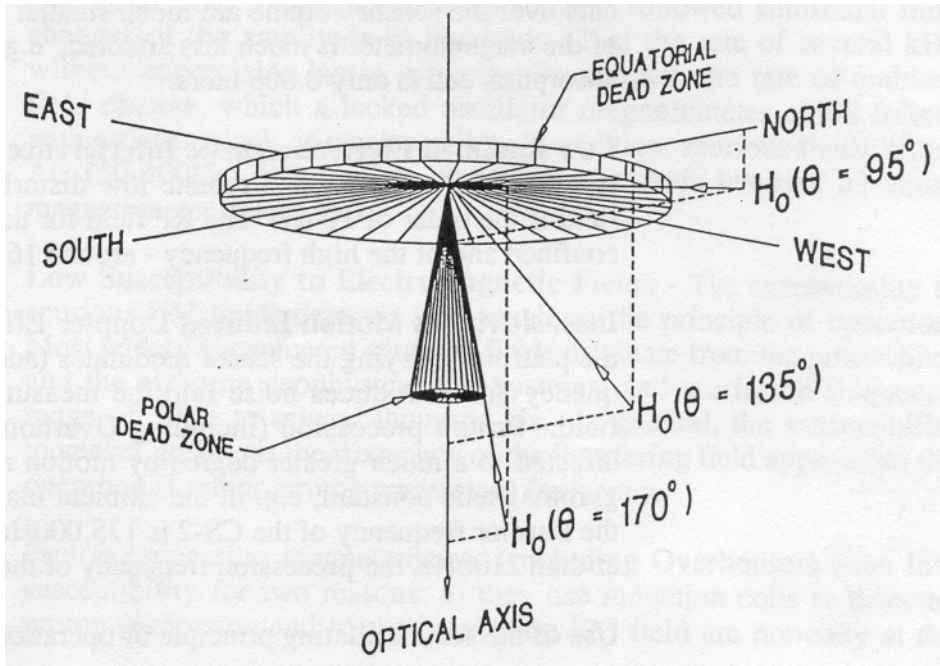
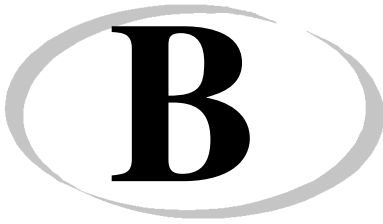

Figure A-3 Southern Operating Hemisphere





CS-3 Block Diagram

As shown on the next page, the CS-3 sensor system includes a variety of sensor and electronic components.



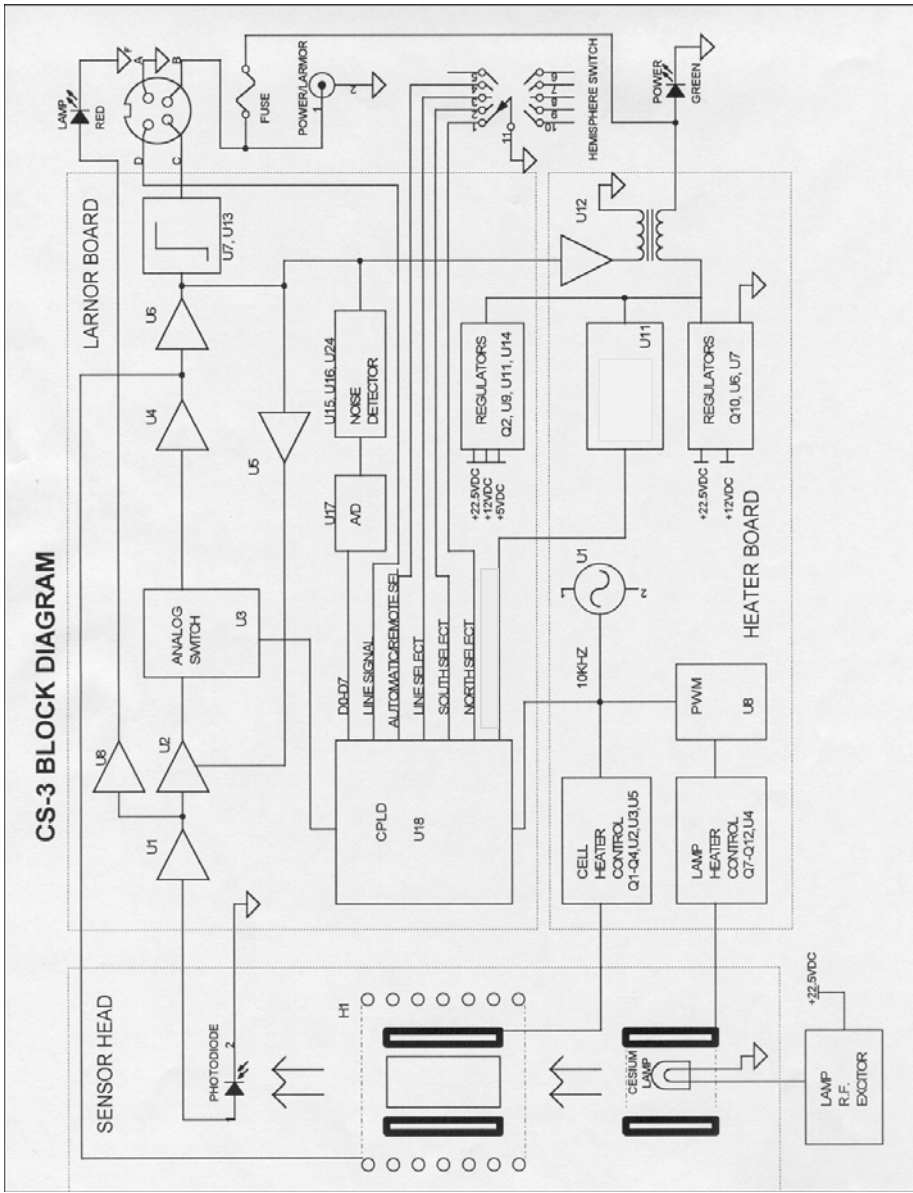

Figure B-1 CS-3 Block Diagram



Index

A

- Absorption cell
 - magnetic field measurement 1-6
 - operating temperature 2-5
- Active zone of CS-3 3-2

C

- Chapter layout scheme 1-3
- Cold start-up
 - power supply current 2-4

G

- Gyromagnetic constant 2-5

H

- Heading error 3-1, 3-4, 5-1
- Heaters 1-7
- Hemisphere control switch
 - automatic 2-8
 - description 1-8
 - electronic 2-7
 - functions 1-9
 - manual 2-7
 - specifications 5-1
 - use for orientation 3-3

I

- I/O connector
 - signals 1-9

L

- Larmour

- amplifier 1-7
- frequency 2-5
 - output signals 2-5
 - theory A-2
- obtaining signal 2-5
- signal amplitude 3-2

- Locked oscillator
 - comparison with 3-20

M

- Magnetic field
 - measurement
 - absorption cell 1-6
- Magnetometer noise 3-8
- Manual symbols 1-4

O

- Operating hemisphere
 - northern 3-2
 - obtaining proper signal 2-8
 - setting 2-7
 - southern 3-3
 - theory A-3
- Optical axis 1-6, 3-2
- Optically pumped magnetometer
 - frequency variation
 - causes 3-1
 - theory A-2
- Orientation
 - in northern hemisphere 3-8
 - in southern hemisphere 3-8

P

- Page Numbering 1-1
- Polar dead zones 3-8
- Powering up



four pin I/O connector 2-4

TNC connector 2-4

Processors

Scintrex MEP series 2-6

R

RF lamp exciter 1-7

S

Scintrex

offices

contacting 5-4

Selecting sensor inclination 3-8

Sensor

electronics

components 1-7

dimensions 5-2

head

active zone 3-2

components 1-5

dimensions 5-2

housing 1-6

housing

power connections 1-7

Sensor decoupler 2-6

Sensor inclination

0° 3-17

22.5° 3-15

47.5° 3-11

67.5° 3-10

90° 3-9

Setting up

mounting guidelines 2-3

procedure 2-2

stabilization 2-2

voltage 2-2

warning before powering up 2-2

Shipping instructions 5-4

Spurious magnetic fields

operating in 2-9

Survey orientations

recommended 3-18

T

Trouble-shooting 4-2 to 4-3

table 4-2

Tumble angle

calculating 3-7

Type styles scheme 1-2

U

Use of gimbals 2-3, 3-4

W

Warranty and repair 5-3



Head Office

222 Snidercroft Road

Unit #1

Concord, Ontario

Canada, L4K 2K1

tel: +1 905 669 2280

fax: +1 905 669 6403

scintrex@scintrexltd.com

SCINTREX

